

TJA1057

High-speed CAN transceiver

Rev. 1 — 30 May 2013

Preliminary data sheet

1. General description

The TJA1057 is a high-speed CAN transceiver that provides an interface between a Controller Area Network (CAN) protocol controller and the physical two-wire CAN bus. The transceiver is designed for high-speed CAN applications in the automotive industry, providing the differential transmit and receive capability to (a microcontroller with) a CAN protocol controller.

The TJA1057 offers a feature set optimized for 12 V automotive applications, with significant improvements over NXP's first- and second-generation CAN transceivers, such as the TJA1050, and excellent ElectroMagnetic Compatibility (EMC) performance. The TJA1057 also displays ideal passive behavior to the CAN bus when the supply voltage is off.

These features make the TJA1057 an excellent choice for HS-CAN networks that only require basic CAN functionality.

2. Features and benefits

2.1 General

- Fully ISO 11898-2 compliant
- Optimized for use in 12 V automotive systems
- Low ElectroMagnetic Emissions (EME) and high ElectroMagnetic Immunity (EMI)
- Compatible with 5 V and 3V3 microcontrollers

2.2 Predictable and fail-safe behavior

- Functional behavior predictable under all supply conditions
- Transceiver disengages from bus when not powered (zero load) or in Silent mode
- Transmit Data (TXD) dominant time-out function
- Undervoltage detection on pin V_{CC}
- Internal biasing of TXD and S input pins

2.3 Protection

- High ESD handling capability on the bus pins (6 kV IEC and HBM)
- Bus pins protected against transients in automotive environments
- Thermally protected



3. Quick reference data

Table 1. Quick reference data

Symbol	Parameter	Conditions	Min	Typ	Max	Unit
V_{CC}	supply voltage		4.75	-	5.25	V
$V_{uvd(VCC)}$	undervoltage detection voltage on pin V_{CC}		3.5	4	4.3	V
I_{CC}	supply current	Silent mode	100	-	800	μ A
		Normal mode; bus recessive	2	5	10	mA
		Normal mode; bus dominant	20	45	70	mA
V_{ESD}	electrostatic discharge voltage	IEC 61000-4-2 at pins CANH and CANL	-6	-	+6	kV
V_{CANH}	voltage on pin CANH	no time limit; DC limiting value	-42	-	+42	V
V_{CANL}	voltage on pin CANL	no time limit; DC limiting value	-42	-	+42	V
T_{vj}	virtual junction temperature		-40	-	+150	$^{\circ}$ C

4. Ordering information

Table 2. Ordering information

Type number	Package		Version
	Name	Description	
TJA1057T	SO8	plastic small outline package; 8 leads; body width 3.9 mm	SOT96-1

5. Block diagram

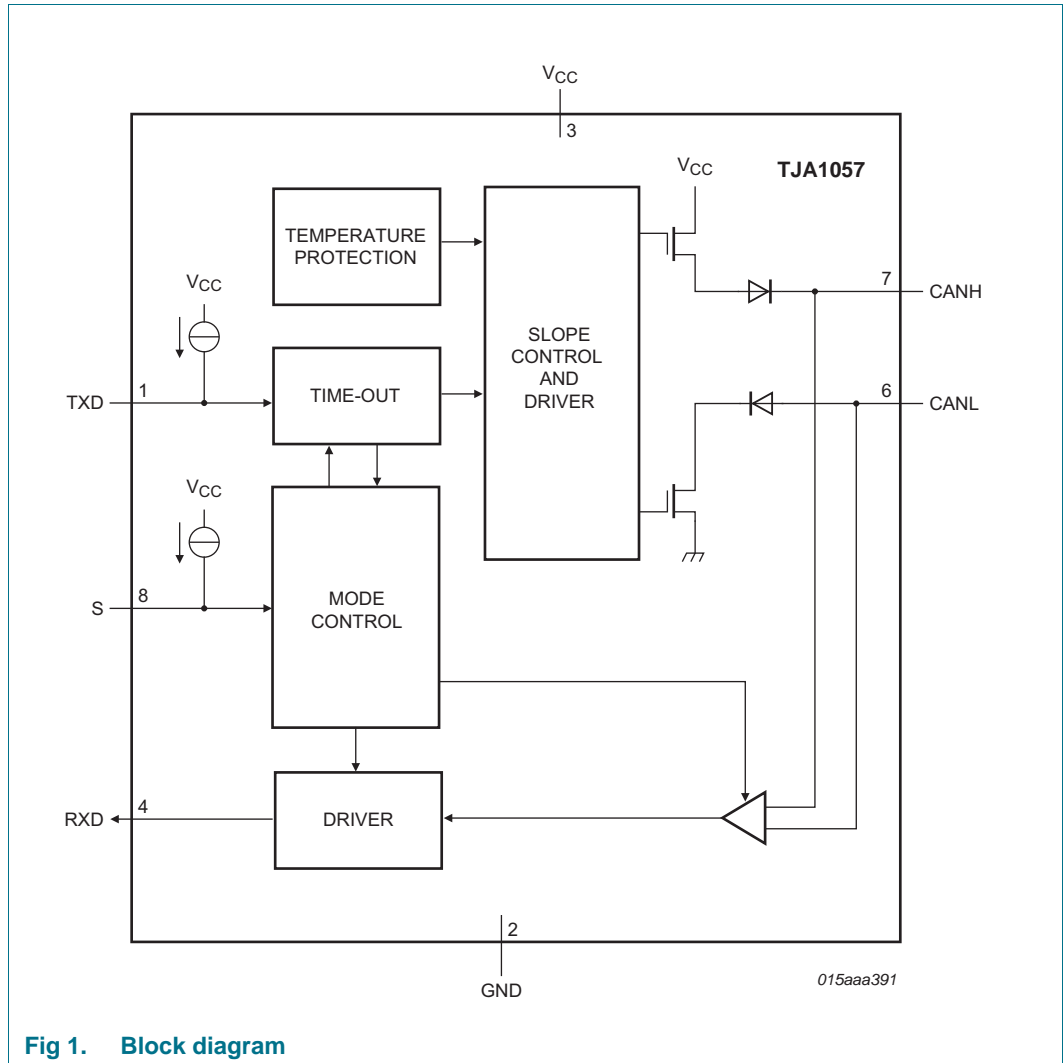

Fig 1. Block diagram

6. Pinning information

6.1 Pinning

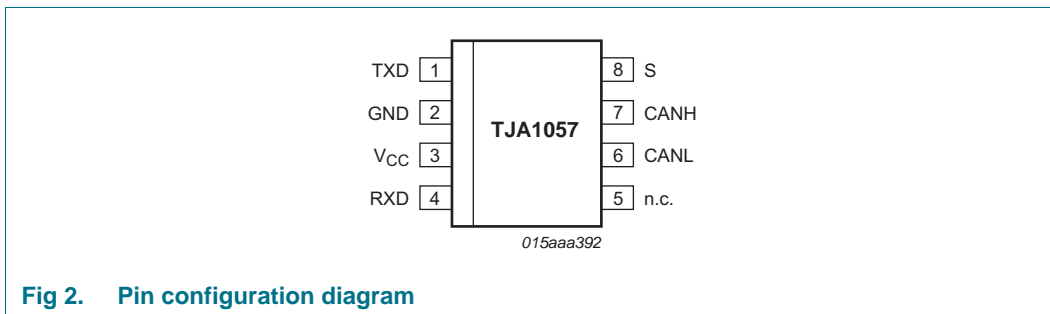

Fig 2. Pin configuration diagram

6.2 Pin description

Table 3. Pin description

Symbol	Pin	Description
TXD	1	transmit data input
GND	2	ground
V _{CC}	3	supply voltage
RXD	4	receive data output; reads out data from the bus lines
n.c.	5	not connected
CANL	6	LOW-level CAN bus line
CANH	7	HIGH-level CAN bus line
S	8	Silent mode control input

7. Functional description

7.1 Operating modes

The TJA1057 supports two operating modes, Normal and Silent. The operating mode is selected via pin S. See [Table 4](#) for a description of the operating modes under normal supply conditions.

Table 4. Operating modes

Mode	Inputs		Outputs	
	Pin S	Pin TXD	CAN driver	Pin RXD
Normal	LOW	LOW	dominant	LOW
		HIGH	recessive	LOW when bus dominant HIGH when bus recessive
Silent	HIGH	x ^[1]	biased to recessive	follows bus

[1] 'x' = don't care.

7.1.1 Normal mode

A LOW level on pin S selects Normal mode. In this mode, the transceiver can transmit and receive data via the bus lines, CANH and CANL (see [Figure 1](#) for the block diagram). The differential receiver converts the analog data on the bus lines into digital data which is output on pin RXD. The slope of the output signals on the bus lines is controlled and optimized in a way that guarantees the lowest possible EME.

7.1.2 Silent mode

A HIGH level on pin S selects Silent mode. The transmitter is disabled in Silent mode, releasing the bus pins to recessive state. All other IC functions, including the receiver, continue to operate as in Normal mode. Silent mode can be used to prevent a faulty CAN controller disrupting all network communications.

7.2 Fail-safe features

7.2.1 TXD dominant time-out function

A 'TXD dominant time-out' timer is started when pin TXD is set LOW. If the LOW state on this pin persists for longer than $t_{to(dom)TXD}$, the transmitter is disabled, releasing the bus lines to recessive state. This function prevents a hardware and/or software application failure from driving the bus lines to a permanent dominant state (blocking all network communications). The TXD dominant time-out timer is reset when pin TXD is set HIGH. The TXD dominant time-out time also defines the minimum possible bit rate of 40 kbit/s.

7.2.2 Internal biasing of TXD and S input pins

Pins TXD and S have internal pull-ups to V_{CC} to ensure a safe, defined state in case one or both of these pins are left floating. Pull-up currents flow in these pins in all states; both pins should be held HIGH in Silent mode to minimize standby current.

7.2.3 Undervoltage detection on pins V_{CC}

If V_{CC} drops below the undervoltage detection level, $V_{uvd(VCC)}$, the transceiver switches off.

7.2.4 Overtemperature protection

The output drivers are protected against overtemperature conditions. If the virtual junction temperature exceeds the shutdown junction temperature, $T_{j(sd)}$, both output drivers are disabled. When the virtual junction temperature drops below $T_{j(sd)}$ again, the output drivers recover once TXD has been reset to HIGH. Including the TXD condition prevents output driver oscillation due to small variations in temperature.

8. Limiting values

Table 5. Limiting values

In accordance with the Absolute Maximum Rating System (IEC 60134). All voltages are referenced to GND.

Symbol	Parameter	Conditions	Min	Max	Unit
V_x	voltage on pin x	DC value			
		on pins CANH, CANL	-42	+42	V
		on pin V_{CC}	-0.3	+6	V
		on any other pin	[1] -0.3	$V_{CC} + 0.3$	V
V_{trt}	transient voltage	on pins CANH and CANL	[2] -150	+100	V
V_{ESD}	electrostatic discharge voltage	IEC 61000-4-2	[3]		
		at pins CANH and CANL	[4] -6	+6	kV
		HBM	[5]		
		at pins CANH and CANL	-6	+6	kV
		at any other pin	-4	+4	kV
		MM	[6]		
		at any pin	-200	+200	V
T_{vj}	virtual junction temperature	CDM	[7]		
		at corner pins	-750	+750	V
		at any pin	-500	+500	V
T_{stg}	storage temperature		[8] -40	+150	°C
			-55	+150	°C

[1] No time limit.

[2] Verified by an external test house to ensure that pins CANH and CANL can withstand ISO 7637 part 3 automotive transient test pulses 1, 2a, 3a and 3b.

[3] IEC 61000-4-2 (150 pF, 330 Ω); direct coupling.

[4] ESD performance of pins CANH and CANL according to IEC 61000-4-2 (150 pF, 330 Ω) has been verified by an external test house. The result is equal to or better than ± 6 kV (unaided).

[5] Human Body Model (HBM): according to AEC-Q100-002 (100 pF, 1.5 k Ω).

[6] Machine Model (MM): according to AEC-Q100-003 (200 pF, 0.75 μ H, 10 Ω).

[7] Charged Device Model (CDM): according to AEC-Q100-011 (field induced charge; 4 pF); grade C3B.

[8] In accordance with IEC 60747-1. An alternative definition of virtual junction temperature is: $T_{vj} = T_{amb} + P \times R_{th(vj-a)}$, where $R_{th(vj-a)}$ is a fixed value to be used for the calculation of T_{vj} . The rating for T_{vj} limits the allowable combinations of power dissipation (P) and ambient temperature (T_{amb}).

9. Thermal characteristics

Table 6. Thermal characteristics

According to IEC 60747-1.

Symbol	Parameter	Conditions	Value	Unit
$R_{th(vj-a)}$	thermal resistance from virtual junction to ambient	SO8 package; in free air	97	K/W

10. Static characteristics

Table 7. Static characteristics

$T_{vj} = -40\text{ }^{\circ}\text{C}$ to $+150\text{ }^{\circ}\text{C}$; $V_{CC} = 4.75\text{ V}$ to 5.25 V ; $R_L = 60\ \Omega$ unless specified otherwise; All voltages are defined with respect to ground. Positive currents flow into the IC.^[1]

Symbol	Parameter	Conditions	Min	Typ	Max	Unit
Supply; pin V_{CC}						
V _{CC}	supply voltage		4.75	-	5.25	V
V _{uvd(VCC)}	undervoltage detection voltage on pin V _{CC}		3.5	4	4.3	V
I _{CC}	supply current	Silent mode; V _{TXD} = V _{CC}	0.1	-	2.5	mA
		Normal mode				
		recessive; V _{TXD} = V _{CC}	2	5	10	mA
		dominant; V _{TXD} = 0 V	20	45	70	mA
Silent mode control input; pin S						
V _{IH}	HIGH-level input voltage		2	-	V _{CC} + 0.3	V
V _{IL}	LOW-level input voltage		-0.3	-	0.8	V
I _{IH}	HIGH-level input current	V _S = V _{CC}	-1	-	+1	μA
I _{IL}	LOW-level input current	V _S = 0 V	-15	-	-1	μA
CAN transmit data input; pin TXD						
V _{IH}	HIGH-level input voltage		2	-	V _{CC} + 0.3	V
V _{IL}	LOW-level input voltage		-0.3	-	0.8	V
I _{IH}	HIGH-level input current	V _{TXD} = V _{CC}	-5	-	+5	μA
I _{IL}	LOW-level input current	V _{TXD} = 0 V	-260	-150	-70	μA
C _i	input capacitance		^[2] -	5	10	pF
CAN receive data output; pin RXD						
I _{OH}	HIGH-level output current	V _{RXD} = V _{CC} - 0.4 V	-8	-3	-1	mA
I _{OL}	LOW-level output current	V _{RXD} = 0.4 V; bus dominant	1	-	12	mA
Bus lines; pins CANH and CANL						
V _{O(dom)}	dominant output voltage	V _{TXD} = 0 V; t < t _{to(dom)TXD}				
		pin CANH	2.75	3.5	4.5	V
		pin CANL	0.5	1.5	2.25	V
V _{dom(TX)sym}	transmitter dominant voltage symmetry	V _{dom(TX)sym} = V _{CC} - V _{CANH} - V _{CANL}	-400	-	+400	mV
V _{O(dif)bus}	bus differential output voltage	V _{TXD} = 0 V; t < t _{to(dom)TXD} R _L = 50 Ω to 65 Ω	1.5	-	3	V
		V _{TXD} = V _{CC} ; bus recessive; no load	-50	-	+50	mV
V _{O(rec)}	recessive output voltage	V _{TXD} = V _{CC} ; no load	2	0.5V _{CC}	3	V
V _{th(RX)dif}	differential receiver threshold voltage	V _{cm(CAN)} = -12 V to +12 V; Normal/Silent mode	^[3] 0.5	-	0.9	V
V _{hys(RX)dif}	differential receiver hysteresis voltage	V _{cm(CAN)} = -12 V to +12 V Normal mode	50	-	300	mV
I _{O(dom)}	dominant output current	V _{TXD} = 0 V; t < t _{to(dom)TXD} ; V _{CC} = 5 V				
		pin CANH; V _{CANH} = 0 V	-100	-70	-40	mA
		pin CANL; V _{CANL} = 5 V / 40 V	40	70	100	mA

Table 7. Static characteristics ...continued

$T_{vj} = -40\text{ °C}$ to $+150\text{ °C}$; $V_{CC} = 4.75\text{ V}$ to 5.25 V ; $R_L = 60\ \Omega$ unless specified otherwise; All voltages are defined with respect to ground. Positive currents flow into the IC.^[1]

Symbol	Parameter	Conditions	Min	Typ	Max	Unit
$I_{O(rec)}$	recessive output current	Normal mode; $V_{TXD} = V_{CC}$ $V_{CANH} = V_{CANL} = -27\text{ V}$ to $+32\text{ V}$	-5	-	+5	mA
I_L	leakage current	$V_{CC} = 0\text{ V}$; $V_{CANH} = V_{CANL} = 5\text{ V}$	-5	-	+5	μA
R_i	input resistance		9	15	28	k Ω
ΔR_i	input resistance deviation	between V_{CANH} and V_{CANL}	-3	-	+3	%
$R_{i(dif)}$	differential input resistance		19	30	52	k Ω
$C_{i(cm)}$	common-mode input capacitance		[2]	-	20	pF
$C_{i(dif)}$	differential input capacitance		[2]	-	10	pF
Temperature detection						
$T_{j(sd)}$	shutdown junction temperature		[2]	185	-	$^{\circ}\text{C}$

- [1] All parameters are guaranteed over the virtual junction temperature range by design. Factory testing uses correlated test conditions to cover the specified temperature and power supply voltage range.
- [2] Not tested in production; guaranteed by design.
- [3] $V_{cm(CAN)}$ is the common mode voltage of CANH and CANL.

11. Dynamic characteristics

Table 8. Dynamic characteristics

$T_{vj} = -40\text{ }^{\circ}\text{C}$ to $+150\text{ }^{\circ}\text{C}$; $V_{CC} = 4.75\text{ V}$ to 5.25 V ; $R_L = 60\text{ }\Omega$ unless specified otherwise. All voltages are defined with respect to ground. Positive currents flow into the IC.^[1]

Symbol	Parameter	Conditions	Min	Typ	Max	Unit
Transceiver timing; pins CANH, CANL, TXD and RXD; see Figure 3 and Figure 4						
$t_{d(\text{TXD-busdom})}$	delay time from TXD to bus dominant	Normal mode	-	65	-	ns
$t_{d(\text{TXD-busrec})}$	delay time from TXD to bus recessive	Normal mode	-	90	-	ns
$t_{d(\text{busdom-RXD})}$	delay time from bus dominant to RXD	Normal mode	-	60	-	ns
$t_{d(\text{busrec-RXD})}$	delay time from bus recessive to RXD	Normal mode	-	65	-	ns
$t_{PD(\text{TXD-RXD})}$	propagation delay from TXD to RXD	Normal mode	50	-	230	ns
$t_{to(\text{dom})\text{TXD}}$	TXD dominant time-out time	$V_{\text{TXD}} = 0\text{ V}$; Normal mode	0.8	3	16	ms

[1] All parameters are guaranteed over the virtual junction temperature range by design. Factory testing uses correlated test conditions to cover the specified temperature and power supply voltage range.

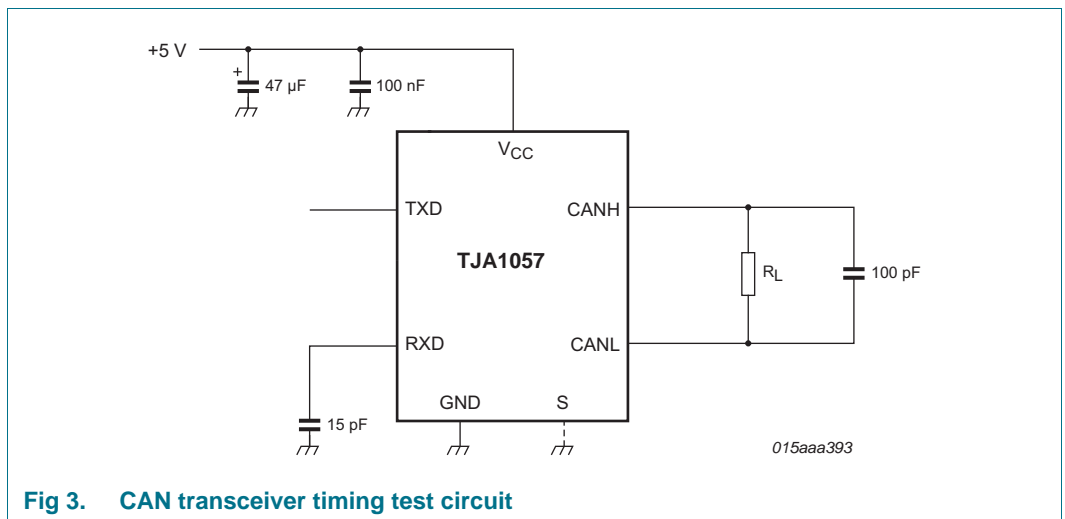

Fig 3. CAN transceiver timing test circuit

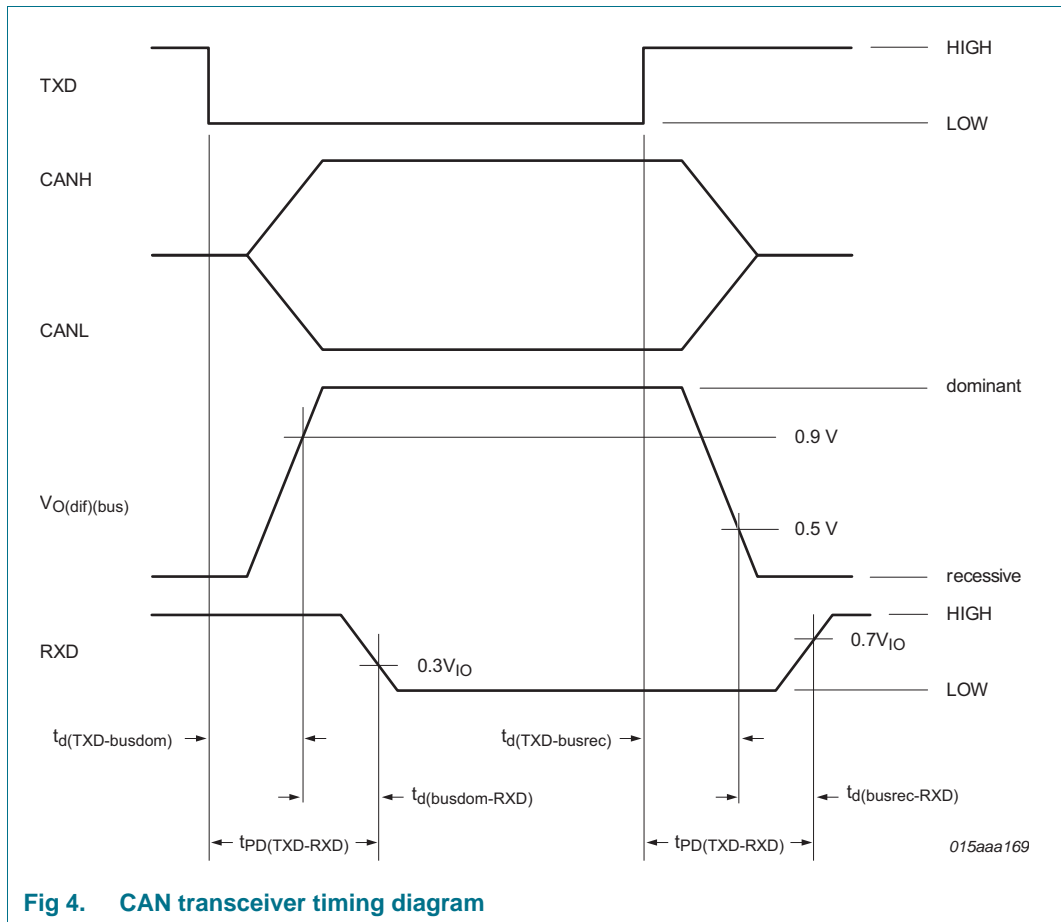

Fig 4. CAN transceiver timing diagram

12. Application information

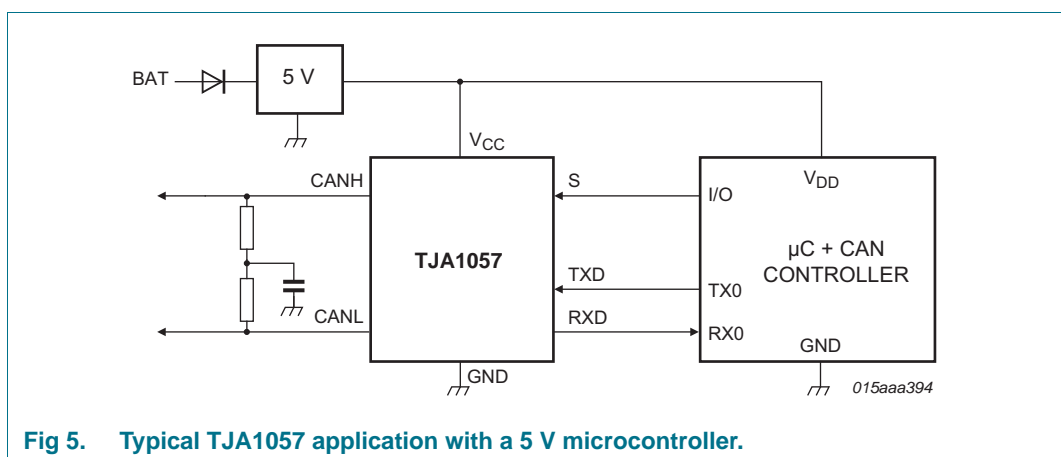

Fig 5. Typical TJA1057 application with a 5 V microcontroller.

13. Test information

13.1 Quality information

This product has been qualified in accordance with the Automotive Electronics Council (AEC) standard *Q100 - Failure mechanism based stress test qualification for integrated circuits*, and is suitable for use in automotive applications.

14. Package outline

SO8: plastic small outline package; 8 leads; body width 3.9 mm

SOT96-1

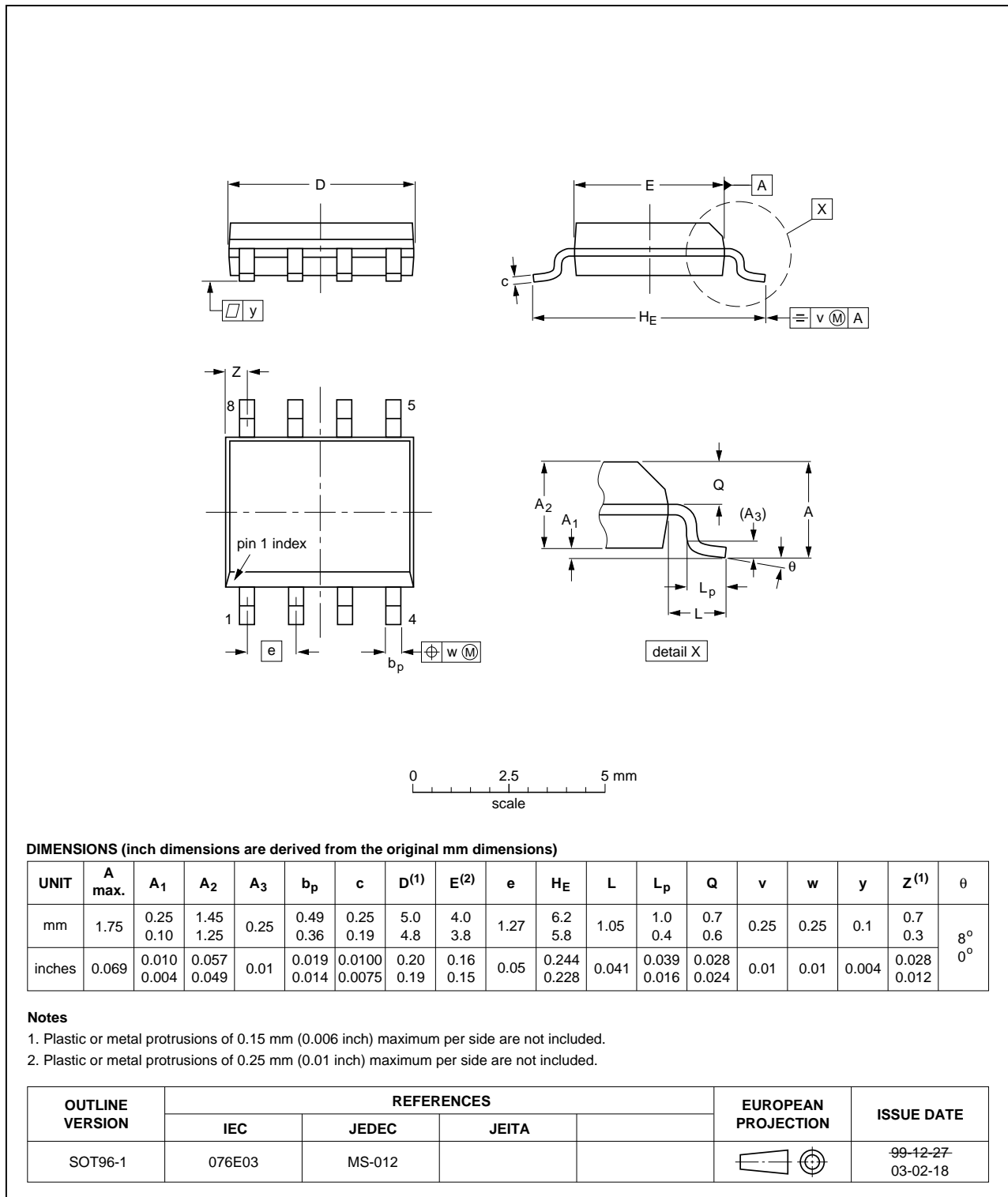

Fig 6. Package outline SOT96-1 (SO8)

15. Handling information

All input and output pins are protected against ElectroStatic Discharge (ESD) under normal handling. When handling ensure that the appropriate precautions are taken as described in *JESD625-A* or equivalent standards.

16. Soldering of SMD packages

This text provides a very brief insight into a complex technology. A more in-depth account of soldering ICs can be found in Application Note *AN10365 "Surface mount reflow soldering description"*.

16.1 Introduction to soldering

Soldering is one of the most common methods through which packages are attached to Printed Circuit Boards (PCBs), to form electrical circuits. The soldered joint provides both the mechanical and the electrical connection. There is no single soldering method that is ideal for all IC packages. Wave soldering is often preferred when through-hole and Surface Mount Devices (SMDs) are mixed on one printed wiring board; however, it is not suitable for fine pitch SMDs. Reflow soldering is ideal for the small pitches and high densities that come with increased miniaturization.

16.2 Wave and reflow soldering

Wave soldering is a joining technology in which the joints are made by solder coming from a standing wave of liquid solder. The wave soldering process is suitable for the following:

- Through-hole components
- Leaded or leadless SMDs, which are glued to the surface of the printed circuit board

Not all SMDs can be wave soldered. Packages with solder balls, and some leadless packages which have solder lands underneath the body, cannot be wave soldered. Also, leaded SMDs with leads having a pitch smaller than ~0.6 mm cannot be wave soldered, due to an increased probability of bridging.

The reflow soldering process involves applying solder paste to a board, followed by component placement and exposure to a temperature profile. Leaded packages, packages with solder balls, and leadless packages are all reflow solderable.

Key characteristics in both wave and reflow soldering are:

- Board specifications, including the board finish, solder masks and vias
- Package footprints, including solder thieves and orientation
- The moisture sensitivity level of the packages
- Package placement
- Inspection and repair
- Lead-free soldering versus SnPb soldering

16.3 Wave soldering

Key characteristics in wave soldering are:

- Process issues, such as application of adhesive and flux, clinching of leads, board transport, the solder wave parameters, and the time during which components are exposed to the wave
- Solder bath specifications, including temperature and impurities

16.4 Reflow soldering

Key characteristics in reflow soldering are:

- Lead-free versus SnPb soldering; note that a lead-free reflow process usually leads to higher minimum peak temperatures (see [Figure 7](#)) than a SnPb process, thus reducing the process window
- Solder paste printing issues including smearing, release, and adjusting the process window for a mix of large and small components on one board
- Reflow temperature profile; this profile includes preheat, reflow (in which the board is heated to the peak temperature) and cooling down. It is imperative that the peak temperature is high enough for the solder to make reliable solder joints (a solder paste characteristic). In addition, the peak temperature must be low enough that the packages and/or boards are not damaged. The peak temperature of the package depends on package thickness and volume and is classified in accordance with [Table 9](#) and [10](#)

Table 9. SnPb eutectic process (from J-STD-020D)

Package thickness (mm)	Package reflow temperature (°C)	
	Volume (mm ³)	
	< 350	≥ 350
< 2.5	235	220
≥ 2.5	220	220

Table 10. Lead-free process (from J-STD-020D)

Package thickness (mm)	Package reflow temperature (°C)		
	Volume (mm ³)		
	< 350	350 to 2000	> 2000
< 1.6	260	260	260
1.6 to 2.5	260	250	245
> 2.5	250	245	245

Moisture sensitivity precautions, as indicated on the packing, must be respected at all times.

Studies have shown that small packages reach higher temperatures during reflow soldering, see [Figure 7](#).

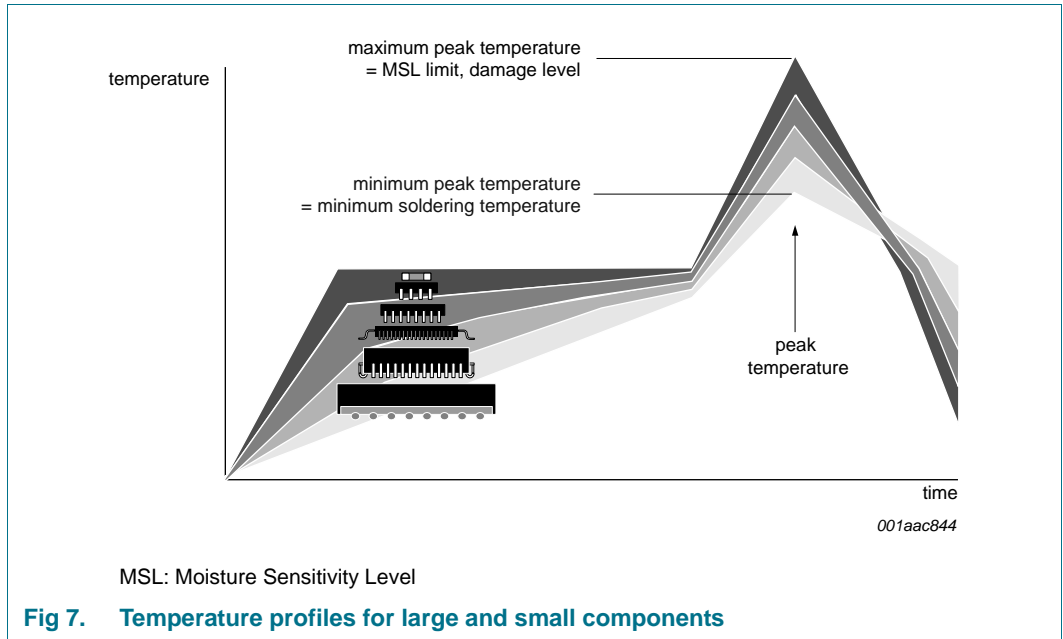

For further information on temperature profiles, refer to Application Note AN10365 “Surface mount reflow soldering description”.

17. Revision history

Table 11. Revision history

Document ID	Release date	Data sheet status	Change notice	Supersedes
TJA1057 v.1	20130530	Preliminary data sheet	-	-

18. Legal information

18.1 Data sheet status

Document status ^{[1][2]}	Product status ^[3]	Definition
Objective [short] data sheet	Development	This document contains data from the objective specification for product development.
Preliminary [short] data sheet	Qualification	This document contains data from the preliminary specification.
Product [short] data sheet	Production	This document contains the product specification.

[1] Please consult the most recently issued document before initiating or completing a design.

[2] The term 'short data sheet' is explained in section "Definitions".

[3] The product status of device(s) described in this document may have changed since this document was published and may differ in case of multiple devices. The latest product status information is available on the Internet at URL <http://www.nxp.com>.

18.2 Definitions

Draft — The document is a draft version only. The content is still under internal review and subject to formal approval, which may result in modifications or additions. NXP Semiconductors does not give any representations or warranties as to the accuracy or completeness of information included herein and shall have no liability for the consequences of use of such information.

Short data sheet — A short data sheet is an extract from a full data sheet with the same product type number(s) and title. A short data sheet is intended for quick reference only and should not be relied upon to contain detailed and full information. For detailed and full information see the relevant full data sheet, which is available on request via the local NXP Semiconductors sales office. In case of any inconsistency or conflict with the short data sheet, the full data sheet shall prevail.

Product specification — The information and data provided in a Product data sheet shall define the specification of the product as agreed between NXP Semiconductors and its customer, unless NXP Semiconductors and customer have explicitly agreed otherwise in writing. In no event however, shall an agreement be valid in which the NXP Semiconductors product is deemed to offer functions and qualities beyond those described in the Product data sheet.

18.3 Disclaimers

Limited warranty and liability — Information in this document is believed to be accurate and reliable. However, NXP Semiconductors does not give any representations or warranties, expressed or implied, as to the accuracy or completeness of such information and shall have no liability for the consequences of use of such information. NXP Semiconductors takes no responsibility for the content in this document if provided by an information source outside of NXP Semiconductors.

In no event shall NXP Semiconductors be liable for any indirect, incidental, punitive, special or consequential damages (including - without limitation - lost profits, lost savings, business interruption, costs related to the removal or replacement of any products or rework charges) whether or not such damages are based on tort (including negligence), warranty, breach of contract or any other legal theory.

Notwithstanding any damages that customer might incur for any reason whatsoever, NXP Semiconductors' aggregate and cumulative liability towards customer for the products described herein shall be limited in accordance with the *Terms and conditions of commercial sale* of NXP Semiconductors.

Right to make changes — NXP Semiconductors reserves the right to make changes to information published in this document, including without limitation specifications and product descriptions, at any time and without notice. This document supersedes and replaces all information supplied prior to the publication hereof.

Suitability for use in automotive applications — This NXP Semiconductors product has been qualified for use in automotive applications. Unless otherwise agreed in writing, the product is not designed, authorized or warranted to be suitable for use in life support, life-critical or safety-critical systems or equipment, nor in applications where failure or malfunction of an NXP Semiconductors product can reasonably be expected to result in personal injury, death or severe property or environmental damage. NXP Semiconductors and its suppliers accept no liability for inclusion and/or use of NXP Semiconductors products in such equipment or applications and therefore such inclusion and/or use is at the customer's own risk.

Applications — Applications that are described herein for any of these products are for illustrative purposes only. NXP Semiconductors makes no representation or warranty that such applications will be suitable for the specified use without further testing or modification.

Customers are responsible for the design and operation of their applications and products using NXP Semiconductors products, and NXP Semiconductors accepts no liability for any assistance with applications or customer product design. It is customer's sole responsibility to determine whether the NXP Semiconductors product is suitable and fit for the customer's applications and products planned, as well as for the planned application and use of customer's third party customer(s). Customers should provide appropriate design and operating safeguards to minimize the risks associated with their applications and products.

NXP Semiconductors does not accept any liability related to any default, damage, costs or problem which is based on any weakness or default in the customer's applications or products, or the application or use by customer's third party customer(s). Customer is responsible for doing all necessary testing for the customer's applications and products using NXP Semiconductors products in order to avoid a default of the applications and the products or of the application or use by customer's third party customer(s). NXP does not accept any liability in this respect.

Limiting values — Stress above one or more limiting values (as defined in the Absolute Maximum Ratings System of IEC 60134) will cause permanent damage to the device. Limiting values are stress ratings only and (proper) operation of the device at these or any other conditions above those given in the Recommended operating conditions section (if present) or the Characteristics sections of this document is not warranted. Constant or repeated exposure to limiting values will permanently and irreversibly affect the quality and reliability of the device.

Terms and conditions of commercial sale — NXP Semiconductors products are sold subject to the general terms and conditions of commercial sale, as published at <http://www.nxp.com/profile/terms>, unless otherwise agreed in a valid written individual agreement. In case an individual agreement is concluded only the terms and conditions of the respective agreement shall apply. NXP Semiconductors hereby expressly objects to applying the customer's general terms and conditions with regard to the purchase of NXP Semiconductors products by customer.

No offer to sell or license — Nothing in this document may be interpreted or construed as an offer to sell products that is open for acceptance or the grant, conveyance or implication of any license under any copyrights, patents or other industrial or intellectual property rights.

Export control — This document as well as the item(s) described herein may be subject to export control regulations. Export might require a prior authorization from competent authorities.

Quick reference data — The Quick reference data is an extract of the product data given in the Limiting values and Characteristics sections of this document, and as such is not complete, exhaustive or legally binding.

Translations — A non-English (translated) version of a document is for reference only. The English version shall prevail in case of any discrepancy between the translated and English versions.

18.4 Trademarks

Notice: All referenced brands, product names, service names and trademarks are the property of their respective owners.

19. Contact information

For more information, please visit: <http://www.nxp.com>

For sales office addresses, please send an email to: salesaddresses@nxp.com

20. Contents

1	General description	1
2	Features and benefits	1
2.1	General	1
2.2	Predictable and fail-safe behavior	1
2.3	Protection	1
3	Quick reference data	2
4	Ordering information	2
5	Block diagram	3
6	Pinning information	4
6.1	Pinning	4
6.2	Pin description	4
7	Functional description	5
7.1	Operating modes	5
7.1.1	Normal mode	5
7.1.2	Silent mode	5
7.2	Fail-safe features	5
7.2.1	TXD dominant time-out function	5
7.2.2	Internal biasing of TXD and S input pins	5
7.2.3	Undervoltage detection on pins V_{CC}	5
7.2.4	Overtemperature protection	6
8	Limiting values	7
9	Thermal characteristics	7
10	Static characteristics	8
11	Dynamic characteristics	10
12	Application information	11
13	Test information	12
13.1	Quality information	12
14	Package outline	13
15	Handling information	14
16	Soldering of SMD packages	14
16.1	Introduction to soldering	14
16.2	Wave and reflow soldering	14
16.3	Wave soldering	14
16.4	Reflow soldering	15
17	Revision history	17
18	Legal information	18
18.1	Data sheet status	18
18.2	Definitions	18
18.3	Disclaimers	18
18.4	Trademarks	19
19	Contact information	19
20	Contents	20

Please be aware that important notices concerning this document and the product(s) described herein, have been included in section 'Legal information'.

© NXP B.V. 2013.

All rights reserved.

For more information, please visit: <http://www.nxp.com>

For sales office addresses, please send an email to: salesaddresses@nxp.com

Date of release: 30 May 2013

Document identifier: TJA1057